

TRAVEL WIDTH- 11'
 TOTAL WEIGHT- 49,000 lbs.
 KING PIN WEIGHT- 13,500 lbs.
 TANDEM SUSPENSION WT-35,500 lbs.

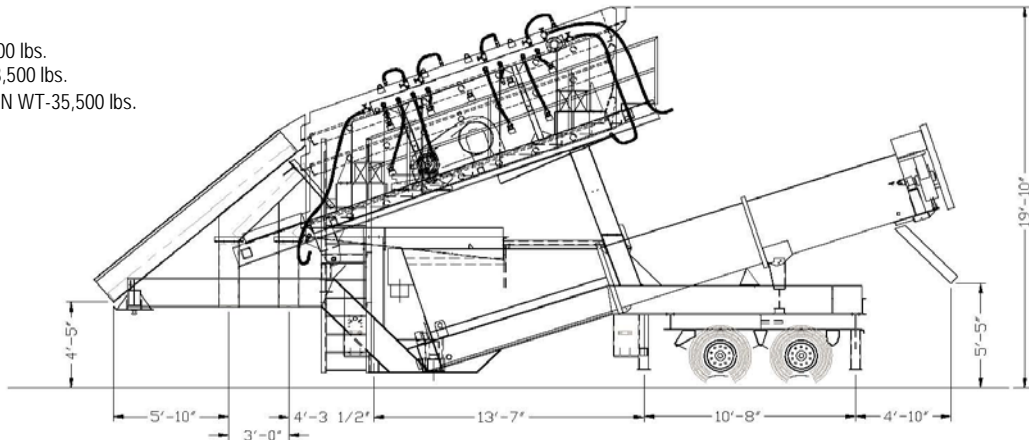

Model 5x16 TD Portable Incline Screen with Single Screw Wash Plant as follows:

- 5' x 16' Simplicity Triple Deck Inclined Two Bearing M120BS Screen includes feed box, replaceable AR Lip liners
- Portable chassis made using heavy-duty I-beam construction with four cribbing support legs with two manual landing jacks for easy truck removal. Chassis includes a double axle suspension, eight (8) 11:00 x 22.5 x 12 ply tires, mounted on 10 hole Budd wheels, 5th wheel, air brakes on two axles, mud flaps and tail lights.
- The unit shall include a 20 HP, 1800 rpm, TEFC electric motor for screen drive and walkway access around three side of the screen with an access ladder.
- The under-screen fines collection flume made using ¼" plate with splash type spray system. Water spray system on all screen decks, flume and washout.
- GreyStone 36" X 25' Single Screw.
- Manifold with the necessary hardware, valves and hoses.
- Heavy-duty discharge chute made from ¼" plate and lined with A.R. plate in heavy wear areas. The discharge chute includes a top deck over chute with discharge to the front of the plant. The middle deck chute discharges to the side, the bottom deck chute with discharges to the opposite side.
- All standard guards provided. Note: Terex|Simplicity does not warrant that our guards will meet all local codes. It is the responsibility of the end user to have them checked by a local inspector.
- Unit to be painted Terex White.



TEREX | SIMPLICITY



5x16 TD Portable Incline Screen with Single Screw Wash Plant as follows:

- 5' x 16' Simplicity Triple Deck Inclined Two Bearing M120BS Screen includes feed box, replaceable AR Lip liners
- Portable chassis made using heavy-duty I-beam construction with four cribbing support legs with two manual landing jacks for easy truck removal. Chassis includes a double axle suspension, eight (8) 11:00 x 22.5 x 12 ply tires, mounted on 10 hole Budd wheels, 5th wheel, air brakes on two axles, mud flaps and tail lights.
- The unit shall include a 20 HP, 1800 rpm, TEFC electric motor for screen drive and walkway access around three side of the screen with an access ladder.
- The under-screen fines collection flume made using ¼" plate with splash type spray system. Water spray system on all screen decks, flume and washout.
- GreyStone 36" X 25' Single Screw.
- Manifold with the necessary hardware, valves and hoses.
- Heavy-duty discharge chute made from ¼" plate and lined with A.R. plate in heavy wear areas. The discharge chute includes a top deck over chute with discharge to the front of the plant. The middle deck chute discharges to the side, the bottom deck chute with discharges to the opposite side.
- All standard guards provided. Note: Terex|Simplicity does not warrant that our guards will meet all local codes. It is the responsibility of the end user to have them checked by a local inspector.
- Unit to be painted Terex White.

TEREX|Simplicity / 212 South Oak St. / Durand, MI / 989-288-3121 TX / 989-288-4113 FX